

SEALED STRAIGHT PLUG CLAMP TYPE

R112.023.000

CABLE 2/50 S

Series : SMC

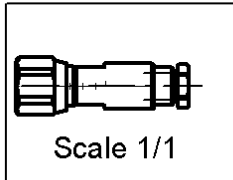
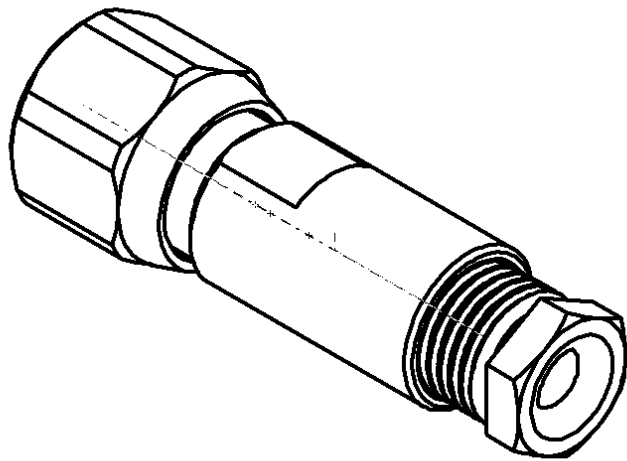
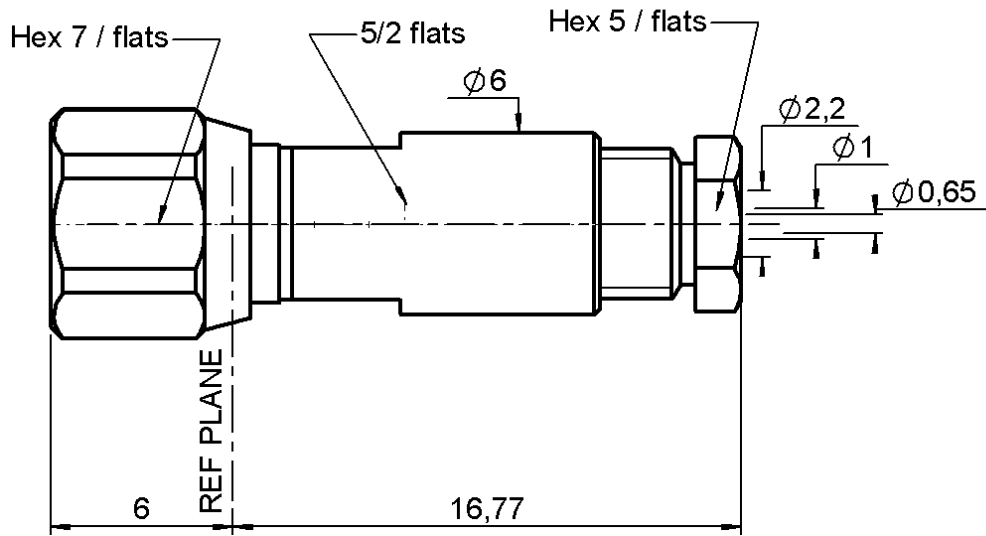

All dimensions are in mm.

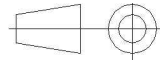

COMPONENTS	MATERIALS	PLATINGS (µm)
BODY	BRASS	GOLD 0.2 OVER NICKEL 2
CENTER CONTACT	BERYLLIUM COPPER	GOLD 1.3 OVER NICKEL 2
OUTER CONTACT	-	-
INSULATOR	PTFE	-
GASKET	CHLOROPRENE	-
OTHERS PARTS	BRASS	GOLD 0.2 OVER NICKEL 2
-	-	-
-	-	-

Issue : 0423 N

In the effort to improve our products, we reserve the right to make changes judged to be necessary.



SEALED STRAIGHT PLUG CLAMP TYPE

R112.023.000

CABLE 2/50 S

Series : SMC

PACKAGING

Standard	Unit	Other
1	-	Contact us

SPECIFICATION

CABLE ASSEMBLY

ELECTRICAL CHARACTERISTICS

Stripping	a	b	c	d	e	f
mm	2.50	1.20	4.50	4.50	0.00	0.00

Impedance		50 Ω
Frequency		0-10 GHz
VSWR	1.80 +	0.000 x F(GHz) Maxi
Insertion loss		0.125 √F(GHz) dB Maxi
RF leakage	- (62 - F(GHz)) dB mini
Voltage rating		250 Veff Maxi
Dielectric withstanding voltage		750 Veff mini
Insulation resistance		1000 MΩ mini

Assembly instruction :

Recommended cable(s)
 RG 178
 KX 21
 RG 196
 RG 178 LC

Cable retention

- pull off **58** N mini
 - torque **NA** N.cm

MECHANICAL CHARACTERISTICS

TOOLING

Center contact retention		
Axial force – Mating end	10	N mini
Axial force – Opposite end	10	N mini
Torque	NA	N.cm mini

Part Number	Description	Hexagon
.	.	.

Recommended torque		
Mating	30	N.cm
Panel nut	NA	N.cm
Clamp nut	70	N.cm
A/F clamp nut	5.000	mm

OTHERS CHARACTERISTICS

Immergeable

Mating life	500	Cycles mini
Weight	3.500	g

ENVIRONMENTAL

Operating temperature	-55°/+100	° C
Hermetic seal	NA	Atm.cm3/s
Panel leakage	0.35	

Issue : 0423 N

In the effort to improve our products, we reserve the right to make changes judged to be necessary.



RADIALL®

SEALED STRAIGHT PLUG CLAMP TYPE

R112.023.000

CABLE 2/50 S

Series : SMC

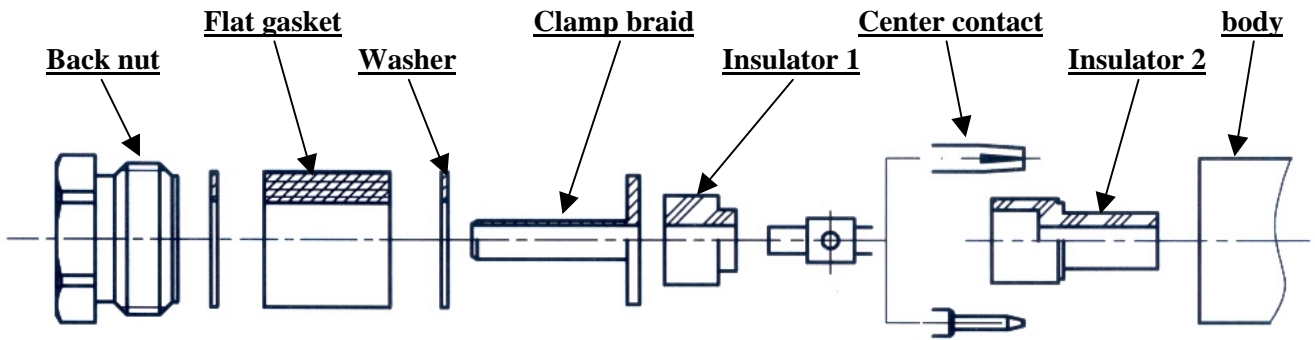

1

Slide the back nut, the first washer, the flat gasket, the second washer onto the cable.
Strip the cable.
Cut 2 slots in the jacket if necessary.

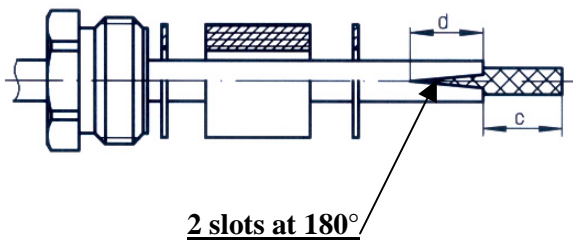

3

Slide the first insulator.
Slide the center contact and solder.
Slide the second insulator

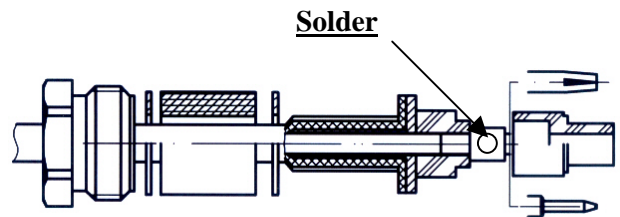

2

Slide the clamp braid sleeve.
Cut the braid flush with the clamp braid sleeve.
Strip off the dielectric.

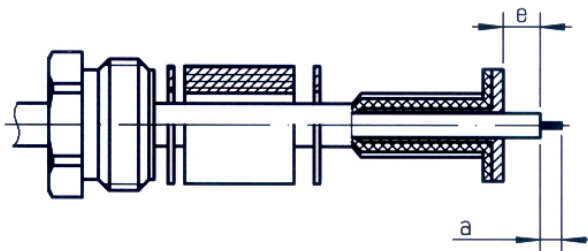

4

Screw sub-assembly into the connector body with the adapted wrench.
Recommended coupling torque (see connector TDS).

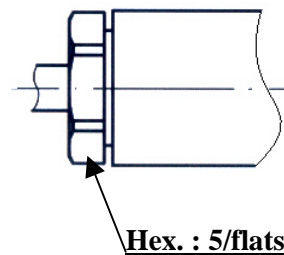

Issue : 0423 N

In the effort to improve our products, we reserve the right to make changes judged to be necessary.

